

## LCDBC Add-on manual as of September 28,2018.

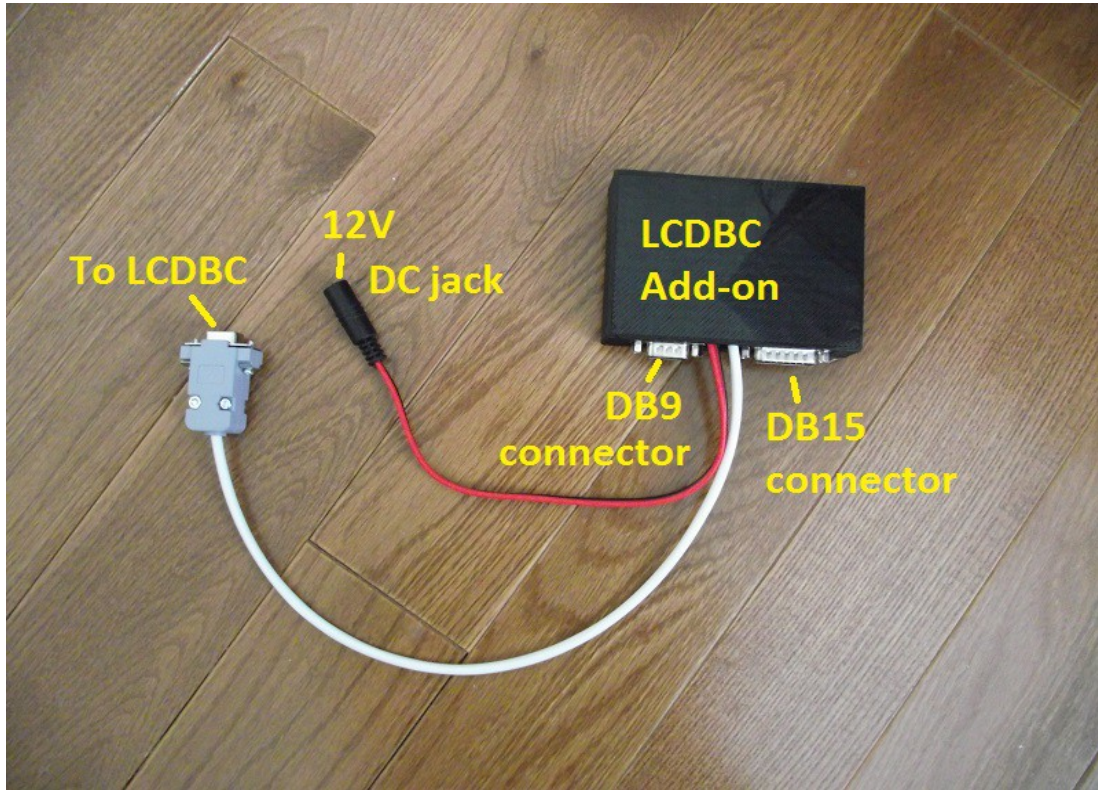

### What is the LCDBC Add-on?

It's a device that expands the LCDBC capability so it can communicate with all computers on our Stealth, 3000GT, GTOs. It uses a new OBD1 or OBD2/MUT cable, and has a larger connector (DB15) to interface with the LCDBC Add-on. The list of computers that it can communicate to are as follows: Engine, Automatic Transmission, SRS (Airbag), ABS, Digital/Automatic Climate Control, Electronic Control Suspension (ECS), ETACS, and Cruise Control.

## Jumper Information

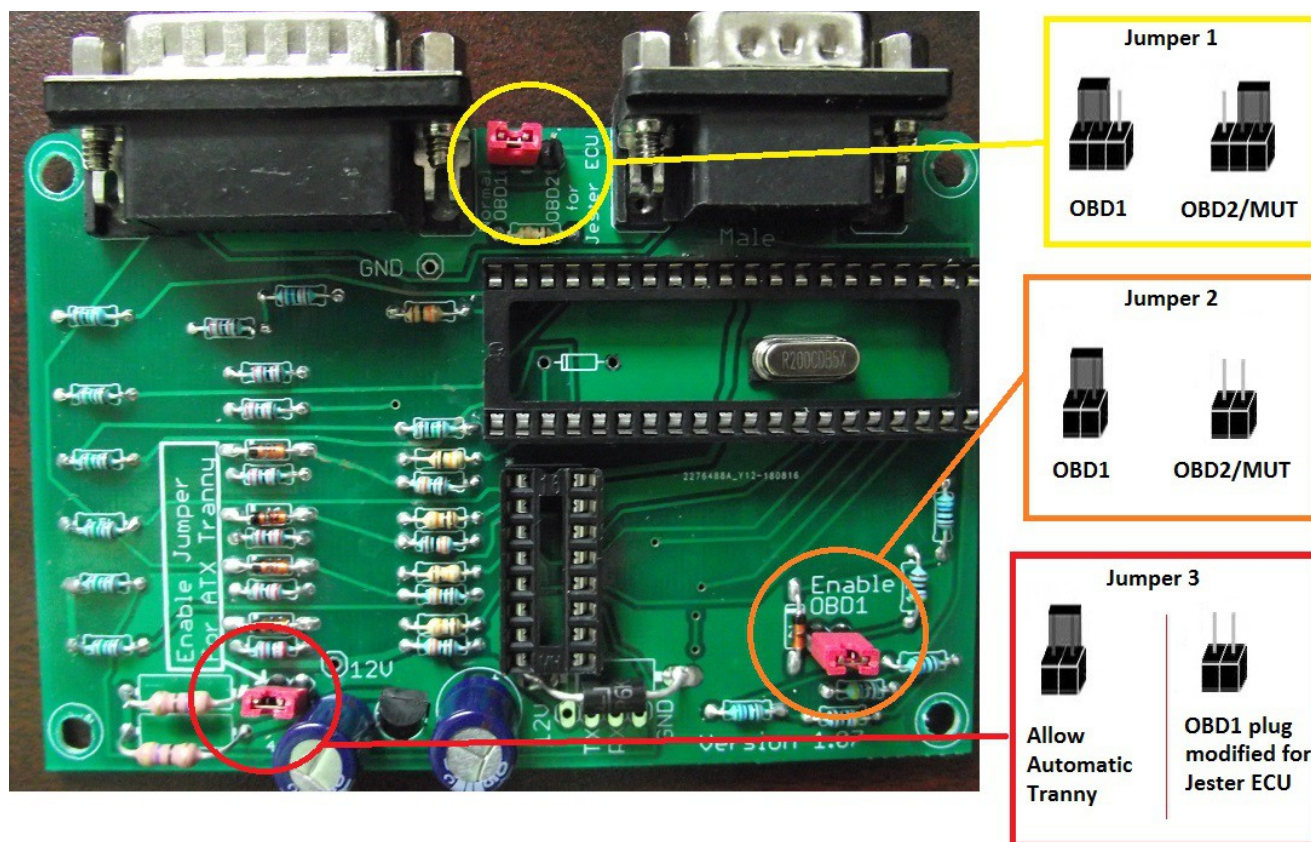

Red jumpers are used here to make them more easily identifiable in this picture above, yours are most likely black. The color have no significance. You must verify all three jumpers are in the correct position if you make changes to your car.

**Jumper 1:** If your car engine ECU is OBD1 (91-93), place the jumper to the left as shown in the picture above. If your car engine ECU is OBD2 or M.U.T. (94-99) place the jumper to the right.

**Jumper 2:** If your car engine ECU is OBD1 (91-93), connect the two pins together with a jumper. If your car engine ECU is OBD2 or M.U.T. (94-99) remove the jumper.

**Jumper 3:** If your OBD1 plug was modified for the Jester Chrome ECU, then remove this jumper. If your OBD1 plug is unmodified and you have an automatic transmission ECU, then connect the two pins together with a jumper.

## Cable requirements

If your car is equipped with a factory OBD1 port, and uses a 1991-1993 Engine ECU, a DB15 OBD1 cable will meet all your needs.

If your car is equipped with a factory OBD1 port, and has a second OBD2 plug coming from a conversion harness for use with a Chrome or Flashable 98/99 Engine ECU then you need two cables. One DB15 OBD1 cable, and one DB9 Enhanced OBD2/MUT cable (can be re-used from LCDBC kit).

If your car is equipped with a factory OBD1 port, and uses a Jester/Chrome Engine ECU with modified OBD1 port, then one DB15 OBD1 cable will meet all your needs. The Jester OBD1 to OBD2 adapter will not be used, and can be put away.

If your car is equipped with a factory OBD2/MUT port (16 pin), one DB15 OBD2/MUT cable will meet all your needs.



## Power requirement

If your LCDBC is currently powered up using ignition position 2 (ACC2), you will have to rewire the LCDBC power using ignition position 1 (ACC1) instead. The reason for this is because of the strange requirements of some electronic control units, such as the early ABS units (91-95), and digital climate control screens. I chose to use accessory socket (fuse number 10) (ACC1) to power mine. Fuse number 10 is highlighted in yellow square.

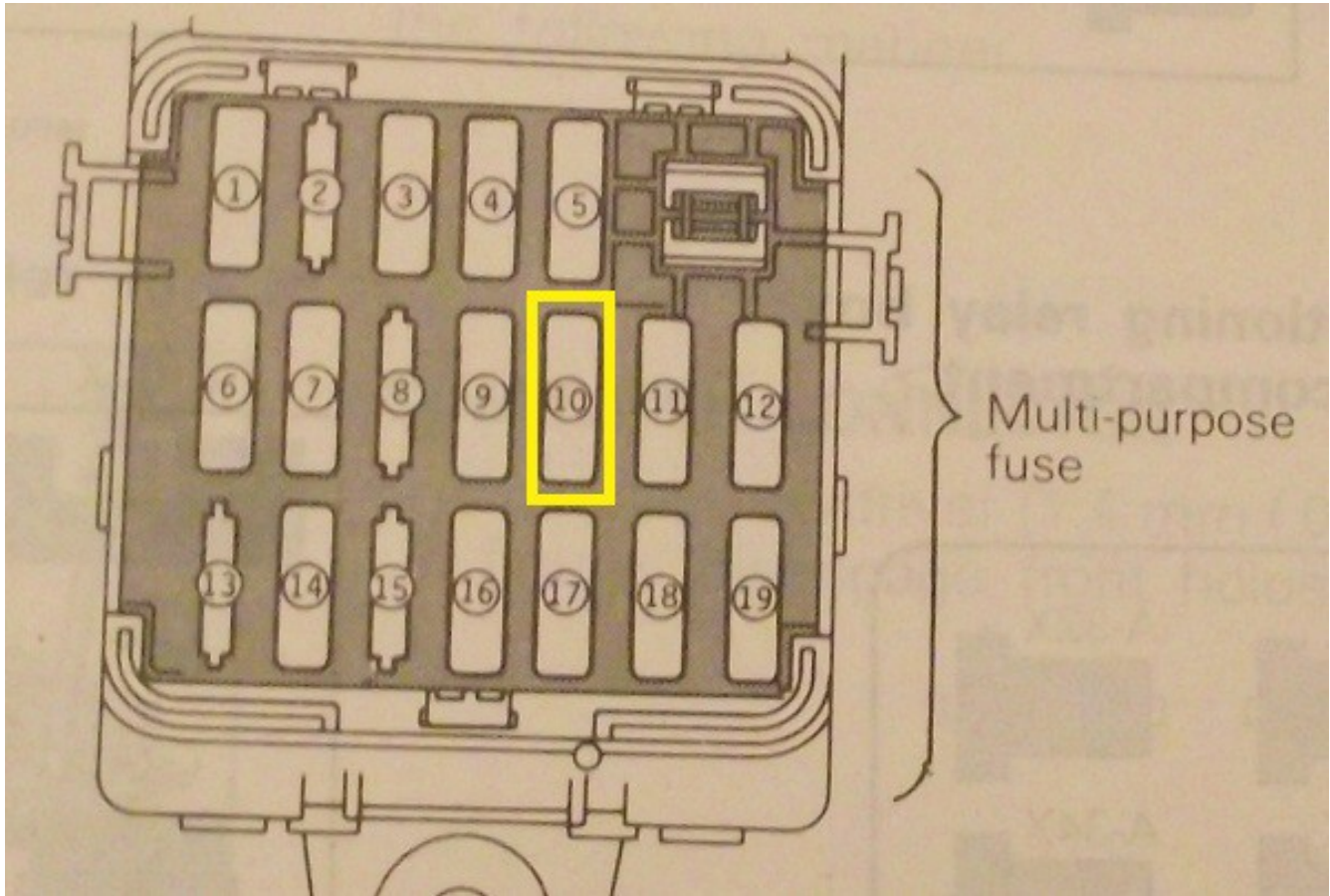

## Digital Automatic Climate Control

Connecting requirements: If you're in ACC2 or ignition position 2 prior to navigating to the Climate Control Menu, you will be required to go back to ACC1 / ignition position 1. The diagnostic mode will be activated at ACC1, and when you move to ACC2 the climate control ECU will see this mode, and communicate with the LCDBC. An A/C HEX ID of 9000 or higher indicates you're connected, all zeros means no connection.

Sensors (with corresponding DTC Code for easier identification):

Room Sensor (Code 11) – interior temperature (sensor located on the ceiling near the back).

Air Inlet Sensor (Code 13) -- incoming air from outside.

A/M Damper (Code 31) – Blend air damper potentiometer input (0-100%). 0% = max cold, 100%=max hot.

Mode Damper (Code 32) – Mode selection damper potentiometer input (0-100%). Low value indicates face position. High value indicates DEF. Position.

Evaporator Sensor (Code 21) –also known as air thermal sensor.

Coolant (Code 15) – On older cars this is just an on / off coolant switch. Newer vehicles indicates actual coolant temperature.

Photo Sensor (Code 25) – 0 mv when it's dark, or something is covering the dash photo sensor. Voltage climbs higher as the brightness increases.

### Diagnostic Tests:

Test Fan Off – air flow off.

Test Fan Low – air flow is set low speed.

Test Fan Medium – air flow is set to medium speed.

Test Fan High – air flow is set to maximum speed.

A/M Test 0% -- max cool temperature setting.

A/M Test 50% -- mid range temperature setting.

A/M Test 100% -- max heat temperature settings.

Blow on Face – change air flow position to face.

Blow on Feet – change air flow position to feet.

Defroster – activate Defroster mode.

A/C Clutch off – turn off air conditioning.

A/C Clutch on – turn on air conditioning.

Fresh air in – adjust air flow mode to outside air.

Recirculate air – adjust air flow mode to recirculate interior air.

### **Scan DTC codes:**

- Code 11: Interior temperature sensor circuit is open (unconnected).
- Code 12: Interior temperature sensor circuit is shorted.
- Code 13: Air Inlet sensor circuit is open (unconnected).
- Code 14: Air Inlet sensor circuit is shorted.
- Code 21: Air temperature sensor is open (unconnected).
- Code 22: Air temperature sensor is shorted.
- Code 31: Blended air damper potentiometer circuit indicates short or open.
- Code 32: Mode selection damper potentiometer circuit indicates short or open.
- Code 41: Blend air damper motor is defective.
- Code 42: Mode selection damper motor is defective.

### **Clear DTC codes:**

Codes can be cleared, if they reappear again, then the original problem still exists.

## **Automatic Transmission ELC-4A/T**

Connecting: If the HEX ID is all zeros, then you're not connected, or the ATX jumper is not shorted (enabled). By default, the ATX jumper is off (not shorted), and is attached to just one pin. The reason this is off by default is because the Jester ECU modification for 1<sup>st</sup> generation vehicles uses the ATX OBD1 pin for 12 volts. The HEX ID is generally F004, or F025 (1998+).

### **Sensors:**

PG-A (r/min) – Pulse Generator A.

PG-B (r/min) – Pulse Generator B.

Ignition signal – Revolutions per minute.

Speed sensor (Code 38) – vehicle speed.

DCCSV duty cycle (Code 49) -- Torque converter clutch

Throttle position sensor (Code 11) – TPS sensor in millivolts.

FLD temperature sensor – fluid / oil temperature.

Inhibitor switch – Park/Neutral, Reverse, Drive, Gear 2, Gear 1 (Low).

Overdrive switch – ON or OFF.

A/C Relay (Code 26) – ON or OFF.

Accelerator switch (Code 24) – ON or OFF.

K/D Servo switch – Kickdown servo switch

Idle position switch – ON or OFF.

Shift position (Code 27) -- Gear position 1,2,3,4.

PCSV – Pressure control solenoid valve

DCCSV (r/min) (Code 47) – Torque converter clutch

P/E/Hold switch – Power / Economy / Hold Switch.

## Diagnostic Test

Test PCSV – Activate Pressure Control Solenoid Valve Actuator

### Scan DTC

Code 11: TPS is shorted  
Code 12: TPS is open  
Code 13: Improperly adjusted or defective TPS.  
Code 14: Improperly adjusted TPS.  
Code 15: Oil temperature sensor is open.  
Code 16: Oil temperature sensor is short.  
Code 17: Oil temperature sensor TM. Fail.  
Code 21: Kickdown servo switch open.  
Code 22: Kickdown servo switch short.  
Code 23: Ignition pulse pickup cable is open.  
Code 31: Pulse Generator A is open.  
Code 32: Pulse Generator B is open.  
Code 41: Shift control solenoid valve A is open.  
Code 42: Shift control solenoid valve A is short.  
Code 43: Shift control solenoid valve B is open.  
Code 44: Shift control solenoid valve B is short.  
Code 45: Pressure control solenoid valve is open.  
Code 46: Pressure control solenoid valve is short.  
Code 47: Torque converter clutch solenoid is open.  
Code 48: Torque converter clutch solenoid is short.  
Code 49: Torque converter clutch system is defective  
Code 51: 1<sup>st</sup> gear ratio incorrect  
Code 52: 2<sup>nd</sup> gear ratio incorrect  
Code 53: 3<sup>rd</sup> gear ratio incorrect  
Code 54: 4<sup>th</sup> gear ratio incorrect  
Code 61: Torque reduction request line is short or open.  
Code 62: Torque reduction request line is open.  
Code 63: Torque reduction request line is short.

### DTC (with associated Fail safe modes)

Code 81: Pulse generator A is open. (Fail-safe 3<sup>rd</sup> gear or 2<sup>nd</sup> gear or low gear)  
Code 82: Pulse generator B is open. (Fail-safe 3<sup>rd</sup> gear or 2<sup>nd</sup> gear or low gear)  
Code 83: Shift control solenoid valve A is open or short. (Fail-safe 3<sup>rd</sup> gear)  
Code 84: Shift control solenoid valve B is open or short. (Fail-safe 3<sup>rd</sup> gear)  
Code 85: Pressure control solenoid valve is open or short. (Fail-safe 3<sup>rd</sup> gear, or 2<sup>nd</sup> gear or low gear)  
Code 86: Gear ratio is incorrect. (Fail-safe 3<sup>rd</sup> gear, or 2<sup>nd</sup> gear or low gear)

### Clear DTC

Codes can be cleared, if they reappear again, then the original problem still exists.



## **Electronically Controlled Suspension**

Connecting: No special requirement, powers up on ACC2 (ignition position 2). Communication speed is very slow and sluggish compared to the Engine ECU. If your HEX ID is all zeros, then you're not connected. A HEX ID of C003 is what you should expect when you connect successfully.

### **Sensors:**

Steering angular velocity sensor 1: ON or OFF.

Steering angular velocity sensor 2: ON or OFF.

Turning steering wheel counterclockwise will produce this result:

Sensor 1: ON, ON, OFF, OFF

Sensor 2: ON, OFF, OFF, ON

Turning steering wheel clockwise will produce this result:

Sensor 1: ON, OFF, OFF, ON

Sensor 2: ON, ON, OFF, OFF

Speed sensors: reports vehicle speed from 0 mph to 87 mph, in increments of 6 mph.

G sensor: 0 to 5000 millivolts

Vehicle stationary: 2000 to 3000 millivolts

A voltage under 500 millivolts, or above 4500 millivolts is considered as defective sensor.

Throttle Position Sensor: 0 to 5000 millivolts.

Stop lamp switch sensor: Activated or not activated. Use your brakes to test.

Front Left Shock: Soft / Medium / Hard actuator setting

Front Right Shock: Soft / Medium / Hard actuator setting

Rear Left Shock: Soft / Medium / Hard actuator setting

Rear Right Shock: Soft / Medium / Hard actuator setting

### **Diagnostic Test**

Test Shock Soft Mode – Activate all actuators and put them into soft mode.

Test Shock Medium Mode – Activate all actuators and put them into medium mode.

Test Shock Hard Mode – Activate all actuators and put them into hard mode.

### **Scan DTC (Fail safe mode)**

Code 11: G sensor is defective (bad road detection disabled)

Code 21: Steering angular velocity sensor circuit is open. (Anti-roll control disabled)

Code 24: Vehicle speed sensor circuit is open. (Shock absorbers default to medium)

Code 61: Front right actuator is defective. (Shock absorbers default to hard)

Code 62: Front left actuator is defective. (Shock absorbers default to hard)

Code 63: Rear right actuator is defective. (Shock absorbers default to hard)

Code 64: Rear left actuator is defective. (Shock absorbers default to hard)

### **Clear DTC**

Codes can be cleared, if they reappear again, then the original problem still exists.

## **SRS (Air bag)**

Connecting: depending on the year model of your vehicle, the communication speed will be either super slow or fast. A HEX ID of all zeros means you are not connected. A HEX ID of 7000 or higher is what you will generally see. Some year model vehicles have two air bags, and therefore additional DTC codes available.

There are no sensor data, just fault code duration. The 7000 model only has one trouble period, this stores how many minutes (9999, or 7 days) has elapsed since it stored the DTC code, or set off the air bag light. The 700D model has a second trouble period.

There is an EEPROM that stores how many times the DTC code has been erased. This shows up as "DTC Erased Times".

### **DTC code**

- Code 11: G-sensor trouble 1 – front impact sensors are shorted.
- Code 12: G-sensor trouble 2 – one of the front impact sensors are open.
- Code 13: G-sensor trouble 3 – both front impact sensors are open.
- Code 21: SQUIB trouble 1 – driver's air bag (SQUIB) are shorted, or is grounded.
- Code 22: SQUIB trouble 2 – driver's air bag (SQUIB) is open.
- Code 24: SQUIB trouble 1 – passenger's air bag (SQUIB) are shorted, or is grounded.
- Code 25: SQUIB trouble 2 – passenger's air bag (SQUIB) is open.
- Code 31: Condenser Voltage High – Capacitor voltage is higher than expected.
- Code 32: Condenser Voltage Low – Capacitor voltage is lower than expected.
- Code 33: Cranking trouble – with 45 seconds of cranking, the SRS ECU circuit detects a fault, crank signal shorted to some power supply circuit.
- Code 34: Connector Unlocked – the lock switch is left open.
- Code 41: Ignition voltage low 1 – Multipurpose Fuse #18 is blown.
- Code 42: Ignition voltage low 2 – Multipurpose Fuse #11 is blown.
- Code 43: SRS Lamp trouble 1 – the SRS warning light are open (blown), or is shorted to ground.
- Code 44: SRS Lamp trouble 2 – the SRS ECU light drive transistor is open.
- Code 45: SRS Diagnostic unit – Bad EEPROM or A/D converter is defective inside SRS ECU.

### **Clear DTC**

Each time you clear a DTC, the SRS ECU keeps track of this, and stores it inside the EEPROM.

## **ABS (1991-1995)**

The early model ABS computers have a special requirement when connecting -- it must enter into ABS diagnostic mode with the ABS light lit up on the dash. If you don't have the ABS light on your dash, you will have to turn the ignition key to IGN1, select ABS menu on the LCDBC, and then turn the ignition key to IGN2.

Retrieving ABS error codes are extremely slow, it takes the ABS module several seconds to transmit wave forms, and these wave forms are then converted into ABS codes with their meaning.

Performing ABS tests take approximately 2 seconds to transmit the request. AWD cars do not have a "Rear Solenoid + Valve Test", so do not be alarmed if nothing happens when you perform this test, as it is meant for FWD cars only.

## **ABS (1996-1999)**

The engine ECU and ABS ECU share the same diagnostic bus, and therefore it is only possible to do one or the other. What this means is that the LCDBC will be unable to communicate with engine ECU while you're examining / monitoring the ABS. And when you exit the ABS menu, it will take 5 seconds to break communication from the ABS ECU, and another 2-3 seconds to establish a new connection to the engine ECU.

# Cruise Control

1. Go to Cruise Control menu on LCDBC.
2. Turn ignition key to position Ignition2.
3. Main Cruise switch OFF (coin tray).
4. Hold steering wheel cruise switch in COAST/SET position (bottom).
5. Flip Main Cruise switch ON (coin tray) using other hand.
6. You now have less than 1 second to move the steering wheel cruise switch to ACC/RES position (top).
7. If you're unsuccessful, repeat steps 3-6. It takes me several attempts to get the cruise control module to go into diagnostic mode successfully.

There are no diagnostic menus to request and view information in real time like the other ECU modules found on our vehicles. Instead Mitsubishi engineers decided to output some wave forms that represents error diagnostic codes, and input checking codes. Error diagnostic codes always start with Code 1 in front, such as Code 11,12,15,16 and 17. Input checking codes start with Code 2 in front, such as 21, 22, 23, etc. Wave forms take several seconds to convey information, so be patient.

## **Error Diagnostic Codes:**

- Code 11: Vacuum pump assembly drive output system out of order.
- Code 12: Vehicle speed signal system out of order.
- Code 15: Control switch out of order – when SET or RESUME switch is kept on continuously for more than 60 seconds.
- Code 16: Cruise control unit is broken.
- Code 17: Throttle Position Sensor (TPS) or closed switch on TPS is out of order.

## **Input Checking Codes:**

- Code 21: SET switch activated
- Code 22: RESUME switch activated
- Code 23: Stop Light switch, brake pedal pressed.
- Code 24: Vehicle speed more than 40 Km/h or 25 MPH.
- Code 25: Vehicle speed less than 40 Km/h or 25 MPH.
- Code 26: Clutch Pedal Switch activated for M/T. Park/Neutral position for A/T.
- Code 27: CANCEL switch activated
- Code 28: Throttle Position Sensor (TPS) voltage is 1.5V or more.
- Code 29: TPS idle switch is OFF, accelerator pedal is depressed.

## **ETACS (Electronic Time and Alarm Control System)**

No codes, menus, or wave forms. Instead what you are observing most of the time is just a single pulse that goes from low to high briefly, the ETACS module is acknowledging that you pressed a button, such as the rear defroster, pop up headlight, etc.

ETACS checklist:

Ignition key positions : ACC, IGN1, IGN2

Rear Defroster switch

Pop-up headlights switch

Door switch

Door lock switch

Wiper Switch

Intermittent Wiper Delay

Washer switch fluid less than 0.6 seconds

Washer wiping 2-3 seconds if more than 0.6 seconds depressed

Prevent door lock, if key is left in ignition

Key Reminder

Dimming Lights (no indication)

Seat Belt warning (no indication)

Seat belt tension timer (no indication)